



## **DIGITAL BANKING SYSTEM WITH PROSPECTIVE OF CONSUMER AWARENESS OF SBI AND ICICI BANK**

**Dr. Riazuddin Ahmed**

Assistant Professor, Komar University of Science and Technology, Sulaymaniyah Region,  
Kurdistan, Iraq

**Abstract:** After the covid 19 pandemic they were a tremendous growth in digital Banking and online Banking system around the world .study was made to build awareness and trust among the digital Banking system in these regions with the consumer adaptation in the digital Banking System . This transformation in transactions with empowers the country economies many recent days many changes took place in the payment system like digital banking system, , Internet Banking, E-cash, Mobile Banking .The objectives of this research paper is to study the positive impact that digitalization of Banking system. The present paper focus on anlysis of the adaptation level of these digital Banking system by customers. The primary data was collected from 384 respondents in Hyderabad region. The data is collected through the structured questionnaire were analyzed by using statistically by using chi square techniques.

**Key words:** Degital payment, E wallets, SBI and ICICI Bank payment System

### **Introductions.**

Financial services are consisting of the financial market such as Bank, Non banking financial Institutions, etc. and theses Financial Institution transfer the financials services from saving to investments. These Services rendered by the Financials institutions are called as Financial Services. Median defines financial services activities.

This financials sector has been growing in term of number and quality financial a of services. After the liberalization of Indian Economy in 1990s, the number of financial services is increasing day by day. New trends and Innovative financials Services have been recognized. These include Commercials Banks, Insurance Companies, merchant banking, institutions, mutual funds, factors, leasing and hire purchase, credit rating, agencies, finance companies etc.

The financial services mean allocation and mobilization of savings and resources. This, includes transformation of financial activities into saving into investments.

Financial services mean the services provided by the financial institutions, These financials institutes consist of a range of organisations which deals managing money, These institutions includes investments banks, brokerages services, insurances services, consumers financials institutes, and non banking financial services etc.

Financial Intermediate means collecting the funds from various group of customer funds and make the funds available for those who need the money in terms of loans to those individual and corporate companies. This institution which helps financial services like banks, investment firms, merchant banks, leasing, and venture capital mutual funds companies etc. These financial services provide operation to the financial markets.

**Automatic Telephonic System (ATS) :** These type of services can avail by the customer through the mobile or normal phone, The toll free no is connected the Automated Telephonic System is facilities the customer to do entire non cash related banking or telephonic, Under this System the customer line is connect with voice recorder which the customer can use a transaction .By press the button on the phone a customer can get information from the banker through the recorded voice systems. Some of the banks offer this type of the services free the customers.

**ATM:.** Automatic Teller Machines is most popular in India as well as the in the world, which enables the customers to withdrawn their money 24hours a day and 7 days in a week, It is advises that customers not only to with draw the money but also to deposit money through the ATMS, The new trends also recognised in the ATMs like Cheque Deposit, Balance Transfer& Funds, Mobile Recharge and Pay the Utility bills.

**E-Mail Banking:** Electronic Mail banking is another trends in Financials Services, Is possible to communicate with the banking Customer by electronic mail or e-mail. The most frequently used E-mail Banking services in account statement at an agreed periodicity to the Customer mail box. E-mail Banking services are not used for banking transactions as a funds transfer and other operational services.

**SMS Banking:** Short Message Services in Banking services are another trends in Marketing of Innovative financial Services. In SMS banking system using customer mobile, it is used by all national and international banks and other financial institutions to massage, notification or alert massage. As soon as customer withdraw the money or transaction or any type of Cheque clearance or balance transfer an alert massage automatically send to customer and balance massage will be send to the mobile phone.

**Internet Banking or Online Banking:** Customers are provided access to bank via Internet. Coupled with computerizations of the branch network of each bank, The Reserve Bank of India suggested to all banks to network their branch offices for intra – bank connectivity for addressing for the twin issues of intra- banking funds transfer and transmission of critical MIS information between branches and controlled offices. Intra –Bank connectivity will ensure the funds department is connected to the controlling office on the one hand and with large business centres on the other.

**Mobile Banking:** Mobile Banking is new trends in area of Innovative Financials Services; The customer can do transaction like transfer of funds, recharge of mobile, pay utility bills through mobile Banking. Customer of the Mobile Banking has to download an app from the Smart phone through he can access the Product details of the Banks.

**Electronic Funds Transfers (EFT) :** Electronic Funds Transfer is a new trends in marketing Financial Services whereby anyone who wants to make payment to another person/ Company /school fees etc can approach to his bank and make the cash payment or give instruction to transfer the funds directly from his bank account to another account. Full detail of receiver account number, account type, bank name, branch name and has to requesting.

**Virtual Banking:** The term virtual banking is the type's electronic delivery of services. Basically, it means that the customer is not interact with the staff of the bank across branches. Most of the

customers are now using electronic delivery financials services with virtual banking. They use new financials services such as credit cards, telebanking, ATMs, retail Banking, Electronic Funds Transfer (EFT) and Electronic Clearing Services (ECS).

**Credit cards:** Credit is new technology development in the electronic banking system. It is also called as plastic money which mean buy now and pay later. It's a chip-based card, the most important is that the banker issues card based on the income of the customer. The limit is sanctioned based on the income of the customer. The user of the card can use the limit which bank has sanctioned the said limit. the customer can use the credit card up the limit the banker has sanctioned the limit and withdraw the money from the any atm. The bankers will provide him interest free period from 30 to 45 days.

### **1. RESEARCH METHODOLOGY**

The study is an explorative and comparative in nature. It has used . Primary data is collected based on the 5 points Scale as well as Schedules and personal interview with the Customers and Bank Manager. Secondary data is collected through published annual reports of the banks, CMIE reports, RBI reports and concerned web sites. Data thus was processed, tabulated and analyzed through growth ratio, Mean, and Standard Deviations. To test the authenticity of finding through Hypothesis, F- Test and Anova are employed

### **2. NEED FOR THE STUDY**

The Study focus on the analysis the emerging causing factor financial services in Banking Sector. To know the performance of SBI and ICICI Banks towards Digital Banking Services System and Consumer Awareness to know the Product and Pricing Strategies of Public and Private Sector banks .

### **3. OBJECTIVES OF THE STUDY**

The following are the objectives of the study.

1. To study the emergence of various Digital financial services in banking sector.
2. To Study the Perception of customers over Product Price Strategies of Towards Digital Payment System of SBI and ICICI Banking,

### **4. HYPOTHESES**

H0: There is no Association of customers demographic factors with the Product Price Place & Promotional Strategies of Towards Digital Banking System

H0: There is no significant difference between the customers perception on the SBI and ICICI bank Customer towards digital Banking system.

### **5. DATASOURCES AND RESEARCH PROBLEMS**

The present study is confined to examine the "A Digital Banking System of SBI and ICICI Banks, A comparative Study. The primary Data is Collected through and Structured Questionnaires and Secondary is Collected through RBI annual reports, Selected Banks Annual Reports, various Banking Journals and Books etc.

### **6 SAMPLE SELECTION AND SIZE**

At First stage two banks SBI Bank from Public and ICICI Bank Private Sector are selected based on the ranking given by the RBIs. The SBI rank as a One of the Largest Bank in the Public Sector in terms of Branches and other Banking Divisions, whereas ICICI Bank is chosen as its 1st Rank in Private Sector Banks in India. The Samples Size is collected .

### **8 Sources of Data**

Primary data has been collected from 384 respondents from the banking customers of State bank of India and ICICI bank. The data is collected from the questionnaires distributed to the sample customers.

### **Review of Literature:**

Abdullah et al. (2019) The main factors – performance expectancy, price value, facilitating conditions, hedonic motivation, habit, system quality and service quality – were found to have a significant impact on actual user behavior. 320 Customers Saudi Arabia Farah et al.

(2018) Most of the predictors of intention, including perceived value, performance expectancy, habit, social influence, effort expectancy, hedonic motivation (except for facilitating condition, perceived risk and trust), are significant. All predictors of user behavior are significant.

(2020) Pakistan Yadgar Taha M. Hama khan Financial Internet Quarterly 2020, vol. 16 / no. 1 An empirical investigation of e-banking in the Kurdistan region of Iraq: the moderating effect of attitude [www.finquarterly.com](http://www.finquarterly.com) University of Information Technology and Management in Rzeszów 48 Alalwan et al.

(2018) Behavioral intention is significantly influenced by performance expectancy, effort expectancy, hedonic motivation, price value and perceived risk; however, social influence does not have a significant impact on behavioral intention. 348 Customers Jordan Alalwan et al.

(2017) Behavioral intention is significantly and positively influenced by performance expectancy, effort expectancy, hedonic motivation, price value and trust. 343 participants Jordan Maruping et al.

(2017) Found two determinants of behavioral expectation and theorize how these determinants influence BE in concert with four key moderators from UTAUT. 321 users of a new IT. USA Torres et al. (2017) Performance expectancy and effort expectancy had a positive impact on the use of financial websites in CoMamudu and Gayovwi (2019)

(2022) The study on “Marketing on Innovative E-Financial Services with the reference to SBI and ICICI Bank” the main factor of the study is focus on the Performance and Perceptions of Innovative E-Financial Services of the Banks of the banking customer and awareness, problems related to Product , Price , Place and Promotions of the banks, published in Volume 7,issue 12 ,International Journal of Innovative Science and Research Technology with ISSN No:2456-2165.[www.ijisrt.com](http://www.ijisrt.com)

**Ravikumar et al, (2019)** examined the impact of digital payments system on the economic growth in India using annual data spanning from 2011 to 2019 on real GDP and digital payments variables which include card payments, clearing corporation operated system, real-time gross settlement, retail e-clearing, paper and other prepaid instruments like m-wallet and employed OLS and the

ARDL co-integration bound technique. The results found significant short-run digital payments impact economic growth. However, the study found no long-run impact on economic growth.

Ekanga, et al, (2020) examined the impact of electronic payment systems on economic growth in Nigeria using annual data from 2009 to 2018 on the transaction from PoS terminals, ATMs terminals, and web (internet) payment as proxies for e-payment systems, while economic growth is represented with real GDP growth. The study employed correlation analysis and ARDL Model. The result indicated the existence of a positive relationship between electronic payment systems and economic growth over the studied period.

Alda as (2021) investigated the association between electronic payment transactions and economic growth employing convenience sampling based on different geographical areas and different income levels of randomly selected countries around the globe. The data on various parameters of electronic transactions like several payments' cards, ATMs, etc., and gross domestic product were used covering the period 2014 – 2018 and employed correlation and regression techniques with SPSS 20.0 software. The result shows no concrete evidence to support or reject the association between the e-payment system and economic growth which was inferred as a country-specific issue. Colombia, while government support did not have a significant impact. 600 participants Colombia.

### Data Analysis's

#### Awareness of Digital Banking System of SBI and ICICI Bank.

The present study has been emphasized on the banking customers' awareness of Digital Banking System financial services. The study has collected primary data through the drafted questionnaire from the SBI and ICICI banking customers. The following is the frequency distribution explains the opinions on the awareness level on the innovative financial services comparison between the SBI and ICICI bank.

**Table No: 1.0 E-Cash services of SBI & ICICI**

<b>Banks</b>	<b>SBI</b>		<b>ICICI</b>	
	<b>Frequency</b>	<b>Percent</b>	<b>Frequency</b>	<b>Percent</b>
<b>Not at all Aware</b>	<b>67</b>	<b>17.4</b>	<b>72</b>	<b>18.8</b>
<b>Slightly Aware</b>	<b>53</b>	<b>13.8</b>	<b>60</b>	<b>15.6</b>
<b>Some What Aware</b>	<b>71</b>	<b>18.5</b>	<b>69</b>	<b>18</b>
<b>Moderately Aware</b>	<b>85</b>	<b>22.1</b>	<b>81</b>	<b>21.1</b>
<b>Extremely Aware</b>	<b>108</b>	<b>28.1</b>	<b>102</b>	<b>26.6</b>

Source: Compiled through Primary Data The above table 1.0 depicts the responses collected through the SBI and ICICI customers. It explains that there is extremely awareness among the customers regarding the E-cash services of SBI (28.1) rather than the ICICI bank (26.6). Most of the customers are somewhat aware of the SBI as well ICICI bank services about the E-cash. There is 22.1% moderate awareness which is more than ICICI bank which is 21.1%, it is higher when compared to SBI bank. Hence it is concluded that there is more awareness about the E-cash among the customers than the ICICI bank.

**Table No- 1.2 M-Cash services of SBI & ICICI**

Banks	SBI		ICICI	
	Frequency	Percent	Frequency	Percent
Not at all Aware	41	10.7	51	13.3
Slightly Aware	58	15.1	73	19
Some What Aware	56	14.6	54	14.1
Moderately Aware	158	41.1	142	37
Extremely Aware	71	18.5	64	16.7

Source: Compiled through Primary Data

The table 1.2. shows about the awareness of M-cash services of the SBI and ICICI banks. It explains about the awareness of the customers about the M-cash in SBI and ICICI banks. It states from the primary responses collected is that there is extreme awareness of 18.5% among the customers of the SBI and 16.7% from the ICICI bank customers. There is no awareness among the people using the SBI and ICICI is 10.7% and 13.3% where it states that there is less awareness among the ICICI customers regarding the M-cash services. Hence it states that ICICI bank need to improve on this aspect to increase its customers.

H0: There is no association between the demographic factors with the awareness of E-Cash.

H1: There is an association between the demographic factors with the awareness of E-Cash.

**Table No- 1.2. Chi-square with regard to the E-Cash**

Banks		Age	Gender	Qualification	Your Profession	Income ( per Month)	Family Size
SBI	chi-square	27.3	10.21	23.65	28.26	25.48	26.75
	Df	16	4	12	16	12	12
	sig.	0.0008	0.0095	0.0025	0.0312	0.0061	0.006
	critical value	26.3	9.49	21.03	26.3	21.03	21.03
ICICI	chi-square	29.26	12.656	22.26	30.26	22.68	24.56
	Df	16	4	12	16	12	12
	sig.	0.0025	0.0036	0.0069	0.0058	0.0047	0.0014
	critical value	26.3	9.49	21.03	26.3	21.03	21.03

Source: Compiled through Primary Data

The above table 4.2.13 explains about the chi square outcome for the awareness of “E-cash” service provided by the SBI. The demographic factor “Age” with the “E-cash” is 27.3, which is greater than critical value 26.3 at degrees of freedom 16, which signifies the Rejection of Null hypothesis indicates that Age of account holder seems to be having significant association with the “E-cash”. Similarly, it seems that Gender and Qualification of the customer are observed to be Reject the null hypothesis. Likewise, Profession group chi calculated value is higher than critical value ( $28.26 > 26.3$ ), which implies reject the H0. It also estimated that Demographic factor’s Family size and Income of customer are shown significant association with the E-cash services provided by the SBI.

It explains about the chi square result for the awareness of “E-cash” service provided by the ICICI. The demographic factor “Age” with the “E-cash” is 29.26, which is greater than critical value 26.3 at degrees of freedom 16, which signifies the Rejection of Null hypothesis indicates that Age of customer seems to be having significant association with the “E-cash”. Similarly, it seems that Gender and Qualification of the customer are observed to be Reject the null hypothesis. Likewise, Profession group chi calculated value is higher than critical value ( $30.26 > 26.3$ ), which implies reject the H0. It also valued that Demographic factor’s Family size and Income of customer are shown significant association with the E-cash services provided by the ICICI.

H0: There is no association between the demographic factors with the awareness of M-cash

H1: There is an association between the demographic factors with the awareness of M-cash.

**Table No- 1 2.Chi-square with respect to the M-cash**

<b>Banks</b>		<b>Age</b>	<b>Gender</b>	<b>Qualification</b>	<b>Your Profession</b>	<b>Income ( per Month)</b>	<b>Family Size</b>
<b>SBI</b>	<b>chi-square</b>	<b>29.13</b>	<b>11.24</b>	<b>23.56</b>	<b>29.15</b>	<b>25.14</b>	<b>26.25</b>
	<b>Df</b>	<b>16</b>	<b>4</b>	<b>12</b>	<b>16</b>	<b>12</b>	<b>12</b>
	<b>sig.</b>	<b>0.0036</b>	<b>0.0052</b>	<b>0.0094</b>	<b>0.0024</b>	<b>0.0031</b>	<b>0.0078</b>
	<b>critical value</b>	<b>26.3</b>	<b>9.49</b>	<b>21.03</b>	<b>26.3</b>	<b>21.03</b>	<b>21.03</b>
<b>ICICI</b>	<b>chi-square</b>	<b>28.12</b>	<b>14.23</b>	<b>21.48</b>	<b>29.21</b>	<b>26.54</b>	<b>24.25</b>
	<b>Df</b>	<b>16</b>	<b>4</b>	<b>12</b>	<b>16</b>	<b>12</b>	<b>12</b>
	<b>sig.</b>	<b>0.0054</b>	<b>0.0078</b>	<b>0.0034</b>	<b>0.0016</b>	<b>0.0018</b>	<b>0.0021</b>
	<b>critical value</b>	<b>26.3</b>	<b>9.49</b>	<b>21.03</b>	<b>26.3</b>	<b>21.03</b>	<b>21.03</b>

Source: Compiled through Primary Data

The above table 4.2.14 represents the chi square result for the “M-cash”. Here the probability of demographic factors is found to be less than 0.05, so study reject the H0. Further, table signifies that Age of the customer is observed from chi square that the Age is having association with the mobile banking services provided by the SBI. Likewise, Gender chi square value is 11.24 and Qualification is 23.56 which are found to be greater than its respective critical value, implies rejection of H0. Income, Profession, Family Size of the customer is observed from chi-square that

their respective chi-square value is greater than critical value. This implies that M-cash is having the significant association with the demographic factors.

It explains about the chi square result for the awareness of “M-cash” service provided by the ICICI. The demographic factor “Age” with the “M-cash” chi-square is 28.12, which is greater than critical value 26.3 at degrees of freedom 16, which signifies the Rejection of Null hypothesis indicates that Age of customer seems to be having significant association with the “M-cash”. Similarly, it seems that Gender and Qualification of the customer are observed to be Reject the null hypothesis. Likewise, Profession group chi calculated value is higher than critical value ( $29.21 > 26.3$ ), which implies reject the  $H_0$ . It also valued that Demographic factor’s Family size and Income of customer are shown significant association with the M-cash services provided by the ICIC

$H_0$ :- There is no association between the Customers’ demographic factor with the awareness of Mobile banking of SBI.

$H_1$ :-There is an association between the Customers’ demographic factors with the awareness of Mobile banking of SBI.

**Table No- 1.3: Chi Square Results Regarding Mobile Banking of SBI/ICICI**

Bank s		Age	Gender	Qualification	Your Profession	Income ( per Month)	Famil y Size
SBI	chi-square	30.45	11.083	36.851	32.852	23.85	26.95
	Df	16	4	12	16	12	12
	sig.	0.0045	0.0032	0.00889	0.0051	0.0054	0.0087
	critical value	26.3	9.49	21.03	26.3	21.03	21.03
ICICI	chi-square	29.61	16.95	26.51	29.652	22.9651	29.51
	Df	16	4	12	16	12	12
	sig.	0.0084	0.0042	0.0045	0.00921	0.0064	0.0078
	critical value	26.3	9.49	21.03	26.3	21.03	21.03

Source: Compiled through Primary Data

The above table 1.3 represents the chi square result for the “Mobile Banking of SBI”. Here the probabilities of demographic factors are found to be less than 0.05, so study reject the  $H_0$ . Further, it can be observed from chi square that the Age is having association with the mobile banking services provided by the SBI. Likewise, Gender chi square value is 11.083 and Qualification is 36.851 which is found to be greater than its respective critical value, implies rejection of  $H_0$ . Income, Profession, Family Size of the customer is observed from chi square that their respective chi square value is greater than critical value indicates the association of these demographic factors with the mobile banking services. Thus it signifies the rejection of  $H_0$  and acceptance of  $H_1$ . Table also represents the chi square result for the “Mobile Banking of ICICI”. Here the probabilities of demographic factors are found to be less than 0.05, so study reject the  $H_0$ . Further, it can be observed from chi square that the Age is having association with the mobile banking services provided by the ICICI. Likewise, Gender chi square value is 16.95 and Qualification is 26.51



which is found to be greater than its respective critical value, implies rejection of H0. Income, Profession, Family Size of the customer is observed from chi square that their respective chi square value is greater than critical value, indicates the association of these demographic factor with the mobile banking services. Thus it signifies the rejection of H0.

H0: There is no significant difference in customers’ perception between the SBI and ICICI banking products and services.

**H1: There is a significant difference in customers’ perception between the SBI and ICICI banking products and services.**

Path diagram 1:

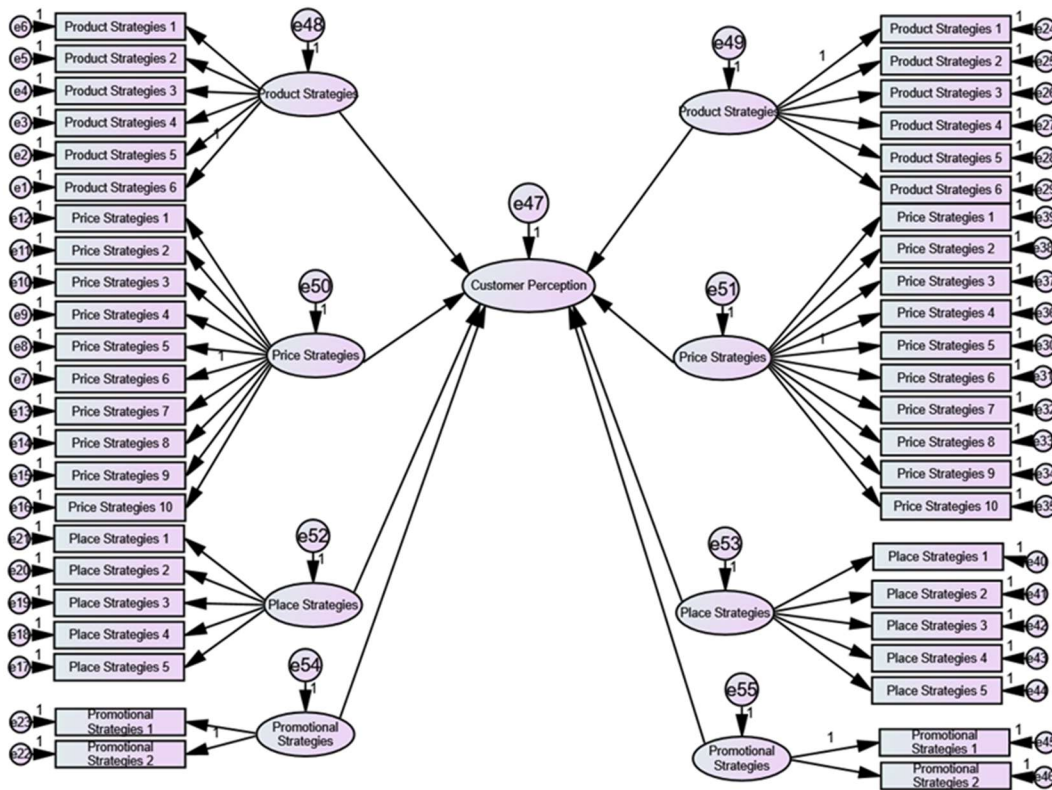

Source: Compiled through Primary Data

The table below shows the coding given to each of the attributes, e.g. the product strategy consists of six parameter codes Product strategy 1, Product strategy 2, Product strategy 3, Product strategy 4, Product strategy 5, Product strategy 6. Likewise, each parameter is a code that is explained in detail as follows.

**Table No- 1.2.1 Goodness of fit index**

		Public
Fit statistic	Recommended Value	Obtained Value
Chi square		465.25
Df		288
Chi square significance	p <= 0.05	0.021

Goodness Fit Index	>0.90	0.985
Adj. Goodness Fit Index	>0.90	0.988
Normed Fit indexes	>0.90	0.916
Relative Fit Index	>0.90	0.915
Comparative Fit Index	>0.90	0.969
Tucker Lewis Index	>0.90	0.936
RMSEA	<0.05	0.017

Source: Compiled through Primary Data

The table 1.2.1 depicts the chisquare of the model is 465.25 seems to be greater than critical vlaue 283.586 which signifies the significant of the model. Goodness fit Index (0.985) and Adjusted Goodness of fit (0.988) is observed to be above the recommended level (<0.90). Normed fit Index and Relative Fit Index of model is satisfactory. Comparative Fit Index and Tucker Lewis Index of the model are seems to be greater than 0.90 which are above the recommend level. Root Mean Square Error for Approximation of the model is less than 0.05 which indicates model strength. Hence, overall result signifies that model is best fit to estimate the regression weight.

Path diagram 2:

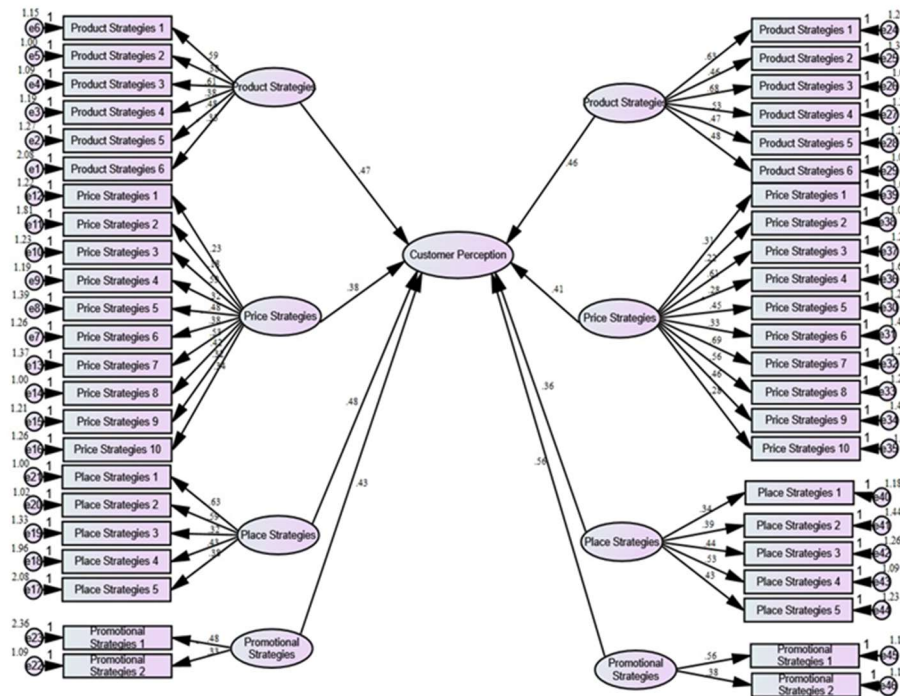

Source: Compiled through Primary Data

Note: There are two basic requirements for the identification of any kind of SEM Model: (1) there must be at least as many observations as free model parameters ( $df \geq 0$ ), and (2) every unobserved (latent) variable must be assigned a scale (metric)

The study has framed the following hypothesis for the statistical examination of customers perception on the SBI and ICICI banks product strategies. The study applied the structural equation model with the help of AMOS software.

H0: There is no significant difference between the customers perception on the SBI and ICICI bank product strategies.

H1: There is a significant difference between the customers perception on the SBI and ICICI bank product strategies.

**Table No-1.2.2**  
**Regression weight regards to Product strategies**

			Estimate Value	P-Value	Estimate Value	P-Value
Offering Innovative Products	<---	Product Strategies	0.592	0.023	0.631	0.012
Adopted new methods to market the banking products to customer	<---	Product Strategies	0.376	0.034	0.462	0.035
SMS alerts from Bank about new Product introductions	<---	Product Strategies	0.612	0.018	0.677	0.014
Uses of Marketing Advisor to promote its products	<---	Product Strategies	0.384	0.033	0.524	0.021
Use a Innovative Products to satisfy it customer	<---	Product Strategies	0.478	0.014	0.468	0.028
Maintaining innovative products at Banks	<---	Product Strategies	0.332	0.039	0.488	0.026

Source: Compiled through Primary Data

The table 4.7.2 shows the regression weight in relation to the product strategies used by SBI and ICICI. Here, the innovation product offering and the SMS alert are two factors which have been found to have a strong impact on the development of retail banking. Adopting new approaches in the marketing of banking products is a technique that has been found to have a mild effect on the perception of the consumer, estimating that SBI holders are less perceptive than ICICI. It synchronized that banks are using digital products to attract their customers, and that the majority of ICICI customers are responding to these strategies than SBI holders. ICICI customers are found to be highly satisfied with the management of innovative products than SBI customers. It also indicates that marketing advisors are shown to be better in ICICI as compared to SBI. However, the p-value of each product strategy tends to be less than 0.05, which indicates the rejection of the Null Hypothesis and the acceptance of the Alternative Hypothesis i.e. the product strategies has a significant difference impact on the customer's perception between the SBI and ICICI banks.

The study has framed the following hypothesis for the statistical examination of customers perception on the SBI and ICICI banks pricing strategies. The study applied the structural equation model with the help of AMOS software.

H0: There is no significant difference between the customers perception on the SBI and ICICI bank pricing strategies.

H1: There is a significant difference between the customers perception on the SBI and ICICI bank pricing strategies.

**Table No-1.2.3**  
**Regression weight regards to Price strategies**

			Estimate Value	P-Value	Estimate Value	P-Value
Charges less transaction on ATMS With drawn	<---	Price Strategies	0.221	0.028	0.307	0.018
Providing High interest rate of Deposits	<---	Price Strategies	0.183	0.043	0.222	0.027
Charges less on Internet / Mobile Banking	<---	Price Strategies	0.587	0.032	0.614	0.024
Charges low interest rate on all types of Loans	<---	Price Strategies	0.318	0.026	0.276	0.032
Charges less rate on cash withdraw on my credit cards	<---	Price Strategies	0.482	0.022	0.456	0.026
Charge low on Mortgagee of other loan bank services	<---	Price Strategies	0.384	0.017	0.328	0.038
Provides loan to New entrepreneurs' with less interest rate	<---	Price Strategies	0.532	0.032	0.687	0.011
Provides me Educational loan for student for going abroad with low interest rate	<---	Price Strategies	0.417	0.011	0.562	0.028
E-Cash charges	<---	Price Strategies	0.316	0.013	0.457	0.016
Getting SMS Alert free of Cost	<---	Price Strategies	0.342	0.012	0.276	0.023

Source: Compiled through Primary Data

Table 1.2.3 signifies the regression weight with respect to Price strategies. The result indicates that provides loan to new entrepreneurs with less interest rate is the pricing strategies which is observed to be favorably affected and seems to the high in both banks. Providing less charges on Internet/ Mobile banking services are found to be moderately impact on the SBI customer, while Strong impact on ICICI customer. Decreasing the Mortgagee loan had shown significant mildly effect on customer perception. Decreasing the interest rate is another factor which are found to be moderately effect on the SBI as well as ICICI customers. Regarding the SMS alert, both the banks had shown significantly influenced, but found to be weak related to customer satisfaction. Towards credit cards rates Customers are adversely percept by the SBI and ICICI customer. It reveals the SBI E-cash Charges estimated value is observed to be lower than ICICI, implies most of the ICICI customer are aware about E-cash charges. Towards the ATM withdrawn limit, SBI as well as ICICI customer are weakly related. Therefore, from p-value, the study concluded that price strategies has a significant differences impact on the SBI and ICICI bank customers perception, implies rejection of H<sub>0</sub> and acceptance of H<sub>1</sub>.

The study has framed the following hypothesis for the statistical examination of customers perception on the SBI and ICICI banks place strategies. The study applied the structural equation model with the help of AMOS software.

**Table No 1.2.6**  
**Impact of Customers Perception on banking strategies SBI and ICICI bank**

Strategies			Estimate Value	P-Value	Estimate Value	P-Value
Product Strategies	<---	Customer Perception	0.467	0.019	0.462	0.014
Price Strategies	<---	Customer Perception	0.382	0.036	0.407	0.018
Place Strategies	<---	Customer Perception	0.481	0.014	0.356	0.029
Promotional Strategies	<---	Customer Perception	0.433	0.022	0.562	***

Source: Compiled through Primary Data

Table 4.7.6 represents the customer perception on the 4P's of SBI/ ICICI. Here, p-value of these strategies are observed to be less than 0.05 which indicates the significant of the model. It signifies that, ICICI promotional strategies are found to be highly impacted on their customer perception than the SBI holder, implies that ICICI are promoting their innovative product in such as manner as to increase the attention of customer. It also found that, product strategies seem to be mildly effect on the effectiveness of services. Price strategies is observed to be impact low under the SBI bank, while in ICICI, Placing strategies seems to be effect low. Hence it is concluded that 4ps' has significant difference between the SBI and ICICI bank customers perception towards innovative products provided by the banks.

#### **Finding Suggestions and Conclusions:**

The study has considered the primary data for the examination of customers' perception on the banking products and services offered by the SBI and ICICI banks. The study applied the structural equation model and derived the following findings.

1. Offering Digital Banking products and promptness in SMS alerts are factors that have been found to have a beneficial impact on the perception of SBI and ICICI customers.
2. The product strategy' Adopting new approaches to market a digital banking product' showed a significant impact on the customer's perception and also reported that ICICI is more aggressive than SBI towards this product strategy.
3. Low perception had shown by SBI customer on the strategy "Maintenance of digital product" (0.332), while ICICI customer on the usage of digital product to satisfy their customers.
4. Provides loan to new entrepreneurs with less interest rate and "Less charge on Internet/ Mobile banking" is the strategy which had found to be immense impact on the ICICI customer, while providing less charge on Internet/Mobile banking had found to highly impact on SBI customer as compare other pricing strategies.
5. Low Interest rate for Education loan had observed to be favorably effect on the perception level of SBI and ICICI customer.
6. Towards E-cash Charge both the customer had percept moderate and the coefficient value has 0.316 (SBI) and 0.457 (ICICI) respectively.

7. SMS alert charges had shown significant impact on the customer perception, but observed to be weakly influenced.
8. It reveals that Credit cards rates are adversely impacted on the perception of SBI and ICICI customer.
9. Customers of SBI and ICICI had shown low perception towards the ATM withdrawn limit.
10. It estimated that the coefficient value of SBI for ATM deposits is 0.427 and ICICI is 0.528, which implies that ICICI customer are highly percept on maintenances of deposits machine.
11. It signifies that, towards the no of branches located, SBI customers are highly impact than ICICI customers, implies location of ICICI branches are not near to their customers' premises.
12. Conducting Social meeting and Loan Mela had significantly effect on the customer perception.
13. It synchronized that Promotional strategies are found to be highly impacted on their customer perception than the SBI holder, implies that ICICI are promoting their innovative product in such as manner as to increase the attention of customer.
14. It found that, product strategies seem to be mildly effect on the effectiveness of SBI and ICICI's services.
15. Price strategies is found to be impact low on the customer perception of SBI, while in ICICI, Placing strategies seems to be effect lo

### **HYPOTHESIS OF THE STUDY**

H0: There is no Association of customers' demographic factors with the Product Price Place & Promotional Strategies of Towards Digital in Banking System

H0: There is an Association of customers' demographic factors with the Product Price Place & Promotional Strategies of Towards Digital in Banking System

The study examined the customer's demographic factors association with the parameters of Product price, place and Promotion strategies towards marketing of innovative financial services. The study applied the statistical method of Chi-square test and the result stated that the calculated values are observed to be more than the critical values and the p values are less than significant value. Hence, the null hypothesis has been rejected and the alternative hypothesis is accepted. Therefore, customers' demographic factors association with the Product Price Place & Promotional Strategies of towards Digital Banking System offered by the SBI and ICICI bank.

H0: There is no significant difference between the customers perception on the SBI and ICICI bank towards digital banking System.

H1: There is a significant difference between the customers perception on the SBI and ICICI bank marketing of digital banking System.

The study examined the customers' perception on the Product Price Strategies of towards digital banking System offered by the SBI and ICICI bank. The study applied the statistical method of Structural Equation Model and result indicates that the estimation values are found to be different for the SBI and ICICI Bank. Hence, the null hypothesis has been rejected and accepted the

alternative hypothesis. Therefore, it has been observed that there is a significant difference of perception of Digital Banking System with the Product, Price, Place and promotional strategies between the SBI and ICICI bank.

### **SUGESSTIONS OF THE STUDY**

- The study observed that the banks Product strategy of demographic factor “Age “and the attributes of “Product Strategy of Digital Banking Systems in banking sector is high. It is suggested both the public and private banks to increase the Digital Banking services in SMS alerts from the banks about the new Product Introductions.
- The Study observed that the banks Price Strategies of Digital Banking System and services of banking sector. It is suggested for the both the banks of SBI and ICICI Bank should provide interest low loans on educations for abroad going students, Loan on Mortgage should be reduced, less rate on debit cards charges-Cash charges should be reduced, Free Cash deposits from ATMs etc.
- The Study has observed that the banks of Place Strategies of Digital Banking and services of banking sector are good. It is suggested for both the banks ATMS, should be increased near by locations,
- The Study has observed that the banks of Promotional strategies of Digital Banking System and Services ,it is suggested for the both banks should provide Free SMS,low interest on educational loans, less charges on ATMwith drawns, and deposits,Mobile banking charges should be reduced,new entrepreneurs loans should be introduced, monthly statement should be free of cost.etc.
- Training programmes should be devised for all staff including call centre and Staff of Direct Sales Associates or Associates of these banks. More importance should be given to upgrade product knowledge and communication skills in such training programmes.
- There is a need for banking staff to have training in the areas of technology and interactive skills.
- The marketing personnel selected by direct sales associates of ICICI bank and SBI should be more qualified, in terms of education, product knowledge communication skills etc.
- In the bank the customer has his first introduction with bank at front desk.
- The person who is presenting the services to the customers is identified with the services offered so the banker or the professional who is offering the banking services to the customers should be good in his appearance, his attitude which should be appealing to the customers.
- Proper dress code, perfect surroundings, attractive interiors, ambience and courteous staff at the counters are must to attract the customers. The personnel at front desk also need to be developed to deliver service quality.
- The bank should attract best talent and retain that talent by right kind of policies in respect of salary, incentives, etc.
- Develop service oriented internal processes Include employees in the banks vision. Right kind of reward to be provided to strong service provider.

- Both the banks need to adopt customer-oriented service delivery, so that the customers loyalty will be enhanced towards banking sector

## CONCLUSIONS

The study concludes to be valuable to ICICI bank and SBI as it is based on the opinion of customers and bank employees (marketing staff). It is useful for other private sector and Public sector banks also in formulating their policies regarding launch of new Digital banking product, in order to reach the level of success achieved by these two banks. It also point out reasons for dissatisfaction among bank customers and provide meaningful solution to their problems. The study conducted will help the private Sector Banks and Public Sector Banks in addressing the marketing problems and difficulties faced by these banks while marketing their services to customers. The study also helps in solving the problems faced by the customers and the effective implementation of marketing strategie/s of private sector and Public sector bank

## BIBLIOGRAPHY

### BOOKS

- Agrawal, A.K. (2005). Services marketing - Stop observe, go, Indian Journal of Marketing, Vol. XXXV, No.5, May, pp. 12-14.
- Agrawal, Anand (2006). Market segmentation in services, Marketing Mastermind, August, pp. 26-29.
- Akamavi, Raphael K. (2005). A research agenda of investigation of product innovation in the financial services sector, Journal of Services Marketing Vol. 19, No.6, pp 359-378.
- Altinkemer, Kemal (2001). Building e-banking services, Communications of the ACM, Vol. 44, No.6, June, pp. 45-47.
- Angelis, Vasilis A. et al. (2005). Customers 'perceived value for private and statecontrolled Hellenic banks, Journal of Financial Services Marketing, Vo1.9. No.4, pp.360-374.
- Angur, Madhukar G. et al. (1999). Service quality in the banking industry: An assessment in a developing economy, International Journal of Bank Marketing, Vol. 17, No.3, pp. 1 16-123.
- Asif, Saadia and Sargeant, Adrian (2000). Modelling internal communications in the financial services sector, European Journal of Marketing, Vol. 34, No. ?h, pp. 299-3 17.
- B hattacharyay, Biswa N. and Ghose, B.K. (1 989). Marketing of banking services in the 90s - Problems and perspectives, Economic and Political Weekly, Vol. 24, February 25, pp. 27-32.
- Banerjee, Abhijit V. et al. (2004). Banking reforms in India, Occasional paper, RBI, June, pp. 1-43.
- Banerjee, Abhijit V. et al. (2005). Bank competition in India, Occasional Paper, RBI, May, pp. 1-16.
- Banerjee, Subhojit and Ray, Reena (2004). Branding strategies for online banks, Professional Banker, April, pp. 18-26.
- Banking Performance snap shot: 2003-04, Chartered Financial Analyst, Vol. X, No. 1 1, November 2004.



- Bauer, Hans H. et al. (2005). Measuring the quality of e-banking portals, *International Journal of Bank Marketing*, Vol. 23, No.2, pp. 153-175.
- Bendapudi, Neeli and Berry, Leonard L. (1997). Customer's motivations for maintaining relationships with service providers, *Journal of Retailing*, Vol. 73, No.1, pp. 15-38.
- Best bank - 2004, *Business India*, August 16-29,2004.
- Bhalla. V.K. (2002). *Management of financial services*, New Del hi: Anmol Publications pvt. Ltd.
- Bhasin, T.M (2003). *E-commerce in Indian Banking*, New Delhi: Authors Press.
- Bhat, Mushtaq A. (2005). Correlates of service quafity in banks: An Empirical Investigation, *Journal of Services Research*, Vol. 5, No. 1, April-September, pp 77-99.
- Bhat, Mushtaq A. (2005). Service quality perceptions in banks: A comparative analysis, *VISION - The Journal of Business Perspective*, Vol. 9, No.1, January-March, pp 11 - 19.
- Bhayani, Sanj ay J. (2006). Performance of the New Indian Private Sector banks: A comparative study, *The Icfai Journal of Management Research*, Vol. V, No. 11, November, pp. 53-70.
- Bisht, N.S. (2002). Liberalisation and its effect on Indian banking, *Finance India*, Vol. XVI, No. 1, March, pp. 147-151.
- Black, Nancy Jo (2002). Modeling Consumer choice of distribution channels: an illustration from firzancial services, *International Journal of Bank marketing*, Vol. 20, No.4, pp. 161 -173.
- Blose, Julia E. et al. (2005). Managing service quality using data envelopment analysis, *Quality Management journal*, Vol. 12, No.2, pp. 7-21.
- Riazuddin Ahmed “The study on “Marketing on Innovative E-Financial Services with the reference to SBI and ICICI Bank” the main factor of the study is focus on the Performance and Perceptions of Innovative E-Financial Services of the Banks of the banking customer and awareness, problems related to Product , Price , Place and Promotions of the banks, published in Volume 7,issue 12 ,*International Journal of Innovative Science and Research Technology* with ISSN No:2456-2165.[www.ijisrt.com](http://www.ijisrt.com)
- Mishra, Vijaya S. (1988). Communication gap in banking, *Indian Journal of Commerce*, Vo. XLI, No. 154, January-March, pp. 11 - 14.
- Mohanty, Ajaya kumar (2004). Indian banks and Base11, *Professional Banker*, July, pp. 45-51.
- Mohanty, Ajaya kumar (2006). Innovations in banking in the reform Era, *Professional Banker*, Vol. VI. No.4, April, pp 28-36.
- Montes, Fco. Javier Llorens et al. (2003). Quality management in banking services: an approach to employee and customer perceptions, *Total Quality Management*, Vol. 14, No.3, pp. 305-323.
- Mukherjee, Avinandan et al. (2002). Performance bench marking and strategic homogeneity of Indian banks, *International Journal of Bank Marketing*, Vol. 20, No.3, pp 122-139.

- Nair, Manju S. (2001). Changing role of services sector: A study on policy impact on banking sector, Ph.D thesis, Thiruvananthapurarn: University of Kerala.
- Nair, Raj agopalan (1 994). Rural bank marketing in Kerala, Ph.D thesis, Thiruvananthapurarn: University of Kerala.
- Narasimham, M. (1996-97). Banking sector reform: The CFS report and after, Prajnan, Vol. XXV, No. 3-4, pp. 221-238.

#### **WEBSITES**

[www. Sbi.com](http://www.Sbi.com)

[www. icicibank.com](http://www.icicibank.com)